



The 4110 is LCN's best performing heavy duty closer designed specifically for institutional and other rugged high traffic applications.

<b>Certifications</b>	Grade 1 - ANSI A156.4, UL 10C, ADA, 100 Hour Salt Spray, Meets BAA - Buy American Act	<b>Cover</b>	<ul style="list-style-type: none"> <li>■ Plastic, Standard</li> <li>■ Metal, Optional</li> </ul>
<b>Body Construction</b>	<ul style="list-style-type: none"> <li>■ Cast Iron Body</li> <li>■ Full Complement Bearing</li> <li>■ 1-1/2" Diameter Piston</li> <li>■ 11/16" Diameter Double Heat Treated Pinion Journal</li> </ul>	<b>Fasteners</b>	Self Reaming and Tapping Screws (SRT)
<b>Fluid</b>	All Weather Fluid	<b>Mounting</b>	Parallel Arm (Push Side)
<b>Handing</b>	Handed	<b>Arms</b>	Extra-Duty arm
<b>Templating</b>	Peel-n-Stick templates - 2-1/2" x 6" Mounting Hole Pattern	<b>Finishes/Colors/Powder Coat</b>	<ul style="list-style-type: none"> <li>■ Aluminum (689)</li> <li>■ Statuary Bronze (690)</li> <li>■ Light Bronze (691)</li> <li>■ Black (693)</li> <li>■ Dark Bronze (695)</li> <li>■ Brass (696)</li> <li>■ Custom colors optional</li> </ul>
<b>Size</b>	Adjustable Spring Size 1-5, or Sized 6, Includes Patented Green Dial		<ul style="list-style-type: none"> <li>■ Optional SRI primer - powder coat only</li> <li>■ Optional plated finishes</li> </ul>
<b>Warranty</b>	30 years		

**Special Templates**

Customized installation templates or products may be available to solve unusual applications. Contact LCN Product Support for assistance.

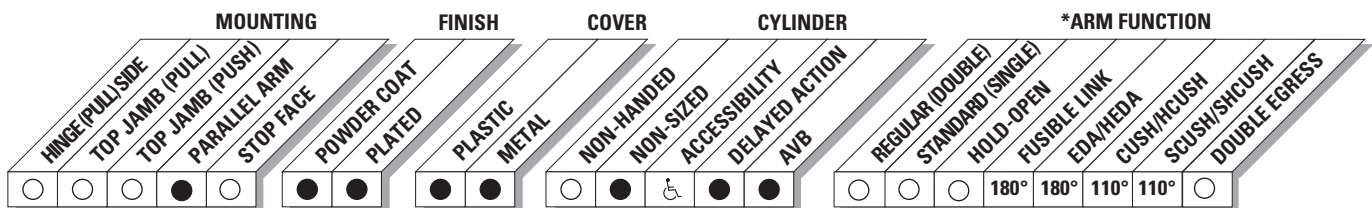

● AVAILABLE  
○ NOT AVAILABLE

♿ Closer available with less than 5.0 lbs. opening force on 36" door.  
\* Maximum opening/hold-open point with standard template.

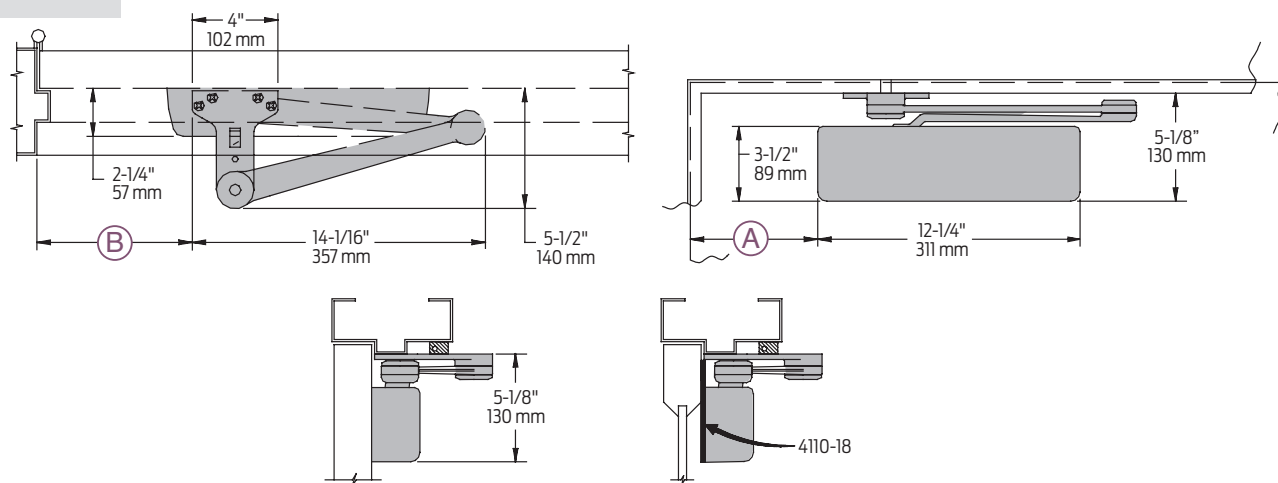

<b>Butt Hinges</b>	Should not exceed 5" (127 mm) in width	
<b>Auxiliary Stop</b>	Recommended at hold-open point, where a door cannot swing 180°, or where CUSH-N-STOP arm is not used	
<b>Clearance</b>	EDA, or CUSH shoe is 5-1/2" (140 mm) from door face	
<b>Top Rail</b>	<ul style="list-style-type: none"> <li>Less than 5-1/8" (130 mm) measured from stop requires PLATE, 4110-18</li> <li>Plate requires 2" (51 mm) minimum measured from the stop</li> </ul>	
<b>Stop Width</b>	Minimum 1" (25 mm)	
<b>Head Frame</b>	Flush or rabbeted requires CUSH FLUSH PANEL ADAPTER, 4110-419	
<b>Reveal</b>	Less than 2-3/4" (70 mm), use CUSH SHOE SUPPORT, 4110-30 with CUSH arms	
<b>Blade Stop Spacer</b>	4110-61 required to clear 1/2" (13 mm) blade stop	
<b>Crush Arm</b>	Requires CUSH SHOE SUPPORT, 4110-30 for fifth screw anchorage with CUSH arms	
<b>Delayed Action</b>	<ul style="list-style-type: none"> <li>Add suffix "DEL" to selected cylinder (eg. 4111 DEL)</li> <li>Not available with 4116 cylinder. Delays closing from maximum opening to approximately 70°</li> <li>Delay time adjustable up to approximately 1 minute</li> </ul>	
<b>Advanced Variable Backcheck</b>	<ul style="list-style-type: none"> <li>Cylinder starts backcheck at approximately 45° instead of the normal 75°</li> <li>Add suffix "AVB" to selected cylinder</li> </ul>	
<b>Maximum opening</b>	EDA or Fusible Link arm can be templated for	CUSH arm can be templated for maximum opening at
	100° A = 5-15/16" (151 mm) B = 7-1/4" (184 mm)	85° A = 8-5/16" (211 mm) B = 9-5/8" (244 mm)
	140° A = 4-7/16" (113 mm) B = 5-3/4" (146 mm)	90° A = 7-11/16" (195 mm) B = 9" (229 mm)
	or 180° A = 2-15/16" (75 mm) B = 2-15/16" (75 mm)	or 110° A = 5-9/16" (141 mm) B = 6-7/8" (175 mm)
	<ul style="list-style-type: none"> <li>Hold-open points up to maximum opening with HEDA or Fusible Link arm</li> </ul>	<ul style="list-style-type: none"> <li>Hold-open point at maximum opening with HCUSH arm</li> <li>Spring Cush hold-open points are approximately 5° less than templated stop point</li> </ul>

### Cylinder



**4111(6)-3071**  
Cast Iron Cylinder Assembly

- Handed
- Standard

### Covers



**4110-72**  
Plastic Cover

- Non-handed
- Standard



Left hand shown

**4110-72MC**  
Metal Cover

- Handed
- Required for plated finishes and custom powder coat finishes
- Optional

### Arms



**4110-3049EDA**  
Hold-Open Arm

- Handed
- Optional
- Provides hold-open function, adjustable at shoe



**4110-3049FL**  
Fusible Link Arm

- Handed
- Releases hold-open function adjustable at shoe when exposed to temperatures above 165° F
- Optional

*NOTE: Check local codes before specifying FL arms. NOT A life safety product!*



**4110-3077CNS**  
Cush-N-Stop Arm

- Non-handed
- Features solid forged steel main arm and forearm with built-in stop in soffit shoe



**4110-3077EDA**  
Extra Duty Arm

- Non-handed
- Features forged, solid steel main and forearm for potentially abusive installations



**4110-3077EDA/ 62G**  
Extra Duty Arm

- Non-handed
- Features forged, solid steel main and forearm for potentially abusive installations
- Optional 4110-62G thick hub shoe for blade stop clearance

### Arms



**4110-3049CNS**  
HCUSH Arm

- Non-handed
- Provides hold-open function with templated stop/ hold-open points.
- Handle controls hold-open function



**4110-3077SCNS**  
Spring CUSH Arm

- Non-handed
- For abusive applications features solid forged steel main arm and forearm with spring loaded stop in the soffit shoe
- Optional



**4110-3049SCNS**  
Spring HCUSH Arm

- Non-handed
- For abusive applications features solid forged steel main arm and forearm with spring loaded stop in the soffit shoe
- Handle controls hold-open function
- Optional

### Installation Accessories



**4110-18**  
Plate

- Required for push side mount where top rail is less than 5-1/8" (130 mm), measured from the stop
- Requires minimum 2" (51 mm) minimum top rail



**4110-30**  
CUSH Shoe Support

- Provides anchorage for fifth screw used with CUSH arm, where reveal is less than 3-1/16" (78 mm)



**4110-61**  
Blade Stop Spacer

- Lowers parallel arm shoe to clear 1/2" (13 mm) blade stop



**4110-419**  
PA Flush Panel Adapter

- Provides horizontal mounting surface for CUSH shoe on single rabbeted or flush frame

### How-to-order 4110 Series closers

#### 1. Specify cylinder size

- 4111 (adjustable from size 1 to 5)
- 4116 (DEL, SHCUSH or HCUSH arm not available)

#### 2. Specify hand

- RH
- LH

#### 3. Select finish

- Standard Powder Coat \_\_\_\_\_  
Aluminum, Dark Bronze, Statuary, Light Bronze, Black, Brass

#### Closer will be shipped with:

- Standard cylinder
- Standard cover
- Extra duty arm
- Self-reaming and tapping screws unless options listed below are selected.

## Closer options

#### Cylinder

- Delayed Action (DEL) (not available with 4116)
- Advanced Variable Backcheck (AVB)

#### Cover

- Metal (MC)

#### Finish

- Custom Powder Coat (RAL) \_\_\_\_\_  
(handed metal cover required)
- Plated Finish, US \_\_\_\_\_  
(handed metal cover required)
- SRI primer (use with powder coat finishes only)

#### Specify Arm

- Hold-Open Extra Duty (HEDA)
- Fusible Link, 165° F (FL)
- Cush-N-Stop (CUSH)
- H-Cush-N-Stop (n/a with 4116 cylinder) (HCUSH)
- Spring Cush (SCUSH)
- Spring H-Cush (n/a with 4116 cylinder) (SHCUSH)
- Extra Duty (EDA)
- H-Extra Duty (HEDA)

#### Screw Packs

- TB\*, Self-Reaming & Tapping (TBSRT)
- Wood & Machine Screw (WMS)
- TB\*, Wood & Machine Screw (TBWMS)
- TORX Machine Screw (TORX)
- TB\* & TORX Machine Screw (TBTRX)  
\* Specify door thickness if other than 1-3/4".

#### Installation Accessories

- Plate, 4110-18
- CUSH Shoe Support, 4110-30
- Blade Stop Spacer, 4110-61
- PA Flush Panel Adapter, 4110-419

#### Special Template

- ST- \_\_\_\_\_

## Table of sizes

- Select closer based on width of door.
- The spring power of non-sized 4111 cylinder is adjustable from size 1 through size 5 and is shipped set to size 3.
- Sized 4116 series cylinders 6.
- Delayed action not available with 4116 cylinder
- H - CUSH and SPRING H-CUSH arm not available with 4116 cylinder.

#### Exterior (and vestibule) door width



#### Interior door width

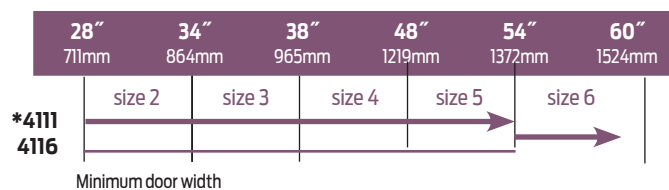

→ Indicates recommended range of door width for closer size. \* Adjustable Size 1 thru 5.

## Reduced opening force 4110 Series closers

**CAUTION!** Any manual door closer, including those certified by BHMA to conform to ANSI Standard A156.4, that is selected, installed and adjusted based on ADA or other reduced opening force requirements may not provide sufficient power to reliably close and latch a door.

Refer to AUTOMATIC OPERATORS section for information on systems that meet reduced opening force requirements without effecting closing power.

	DOOR WIDTH	36"	42"	48"
	8.5* lbs.	4111	4111	4111
5.0* lbs.	4111	4111	4111	

\* Maximum opening force.